

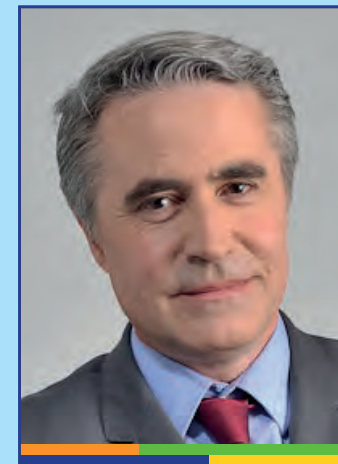

Broader. Better. Together.
ASCO. AVENTICS. TESCOM. TopWorx.





Dear colleagues,

I would like to welcome you all to the 2018 EMEA sales meeting, especially our new colleagues from Aventics. The event provides the perfect opportunity to gain a greater understanding of the complementary products, channel presence, customer relationships, capabilities and expanded global presence provided by the recent acquisition.

As you will be aware, Aventics is a world leader in the manufacture of pneumatic components and systems. Aventics will be integrated within the Fluid & Motion Control business to complement our ASCO, ASCO Numatics, TESCO and TopWorx brands. Aventics will play a key role in helping to strengthen our capabilities in key hybrid, machine and factory automation applications, including food and beverage, packaging, automotive and medical equipment. These are important markets for Emerson, and Aventics' expertise enhances our ability to solve challenges and enlarges our customised solutions capabilities across the widest range of applications, removing complexity and ensuring projects are delivered with speed.

We must ensure the transition is seamless for our customers, while taking the opportunity to present the benefits of the industry's widest range of fluid automation products and solutions. To provide an introduction into the expanding range, we have created a simple sticker book that positions the Aventics products within the wider Fluid & Motion Control portfolio. I hope you are successful in completing the collection and more importantly will see potential opportunities for our business.

Please take every opportunity to position Emerson as the most capable global provider of fluid automation technologies and ensure customers are aware that we are ideally placed to help meet their business goals. This will enable us to grow our sales to become a global leader in the Fluid Automation market.

Jean Louis Tenu
 President Machine Automation & EMEA
 Emerson Automation Solutions

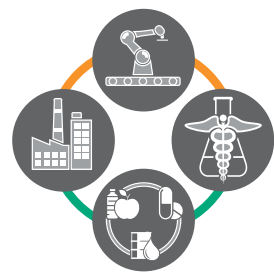

Broader. Better. Together.
 ASCO. AVENTICS. TESCO. TopWorx.

Machine & Factory Automation	4	Commercial Vehicles	20
Analytical & Medical	14	Marine	22
Industrial & Process	17	Tesco™	24
Specials & Solutions	19	TopWorx™	26

ASCO Numatics™ Series 651, 652, 653 air preparation products



ASCO Numatics™ Series 651, 652, 653 air preparation products

Broad range of products and accessories make selection easy

- Series consists of filters, regulators, filter regulators, lubricators, soft starts, quick exhausts, diverter blocks and shut off valves
- Port sizes from 1/8 to 1", flow rates up to 10 000 l/min
- Wide variety of options, including low profile gauge, round gauge, digital gauge or digital pressure switch

Typical industries

- Food & Beverage
- Water and Wastewater
- Automotive & Tyre
- Life Science



AVENTICS™ Series AS1, AS2, AS3, AS5 air preparation products



AVENTICS™ Series AS1, AS2, AS3, AS5 air preparation products

Comprehensive air supply management – configurable to cover any need

- Lighter duty environments (polymer body)
- Wide range of options available, e.g. machine safety, IloT

Typical industries

- General Industry
- Industrial Automation



AVENTICS™ Series CCI compact cylinders



AVENTICS™ Series CCI compact cylinders

Compact – Robust – Economical

- Industrial automation
- For narrow and short installation space
- Wide product portfolio
- Bore sizes from Ø 16-100 mm

Typical industries

- Industrial Automation



AVENTICS™ Series MSS – Modular Sealing System

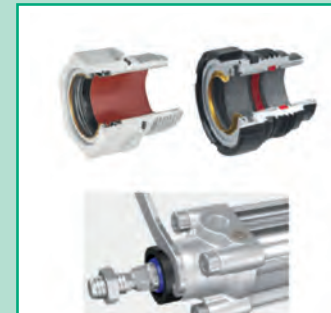

AVENTICS™ Series MSS – Modular Sealing System

Modular sealing system – advantages that pay off

- For Cylinder according to ISO 15552
- Five different scraper modules each to comply with all requirements
- Allows easy replacement without removing the cylinder
- Minimum maintenance costs, low downtimes

Typical industries

- Food & Beverage
- Chemical
- Textile
- Automotive
- Woodworking



ASCO Numatics™ Series 437 tie rod cylinders



ASCO Numatics™ Series 437 tie rod cylinders

CNOMO cylinders available on fast delivery

- Double acting tie rod cylinder
- Complies with CNOMO standards
- Wide range of mountings and sensors

Typical industries

- Automotive & Tyre



ASCO Numatics™ Series 438 round cylinders



ASCO Numatics™ Series 438 round cylinders

Compact ISO cylinder, from order to dispatch in 4 hours

- Complies with ISO 6431, interchangeable with ISO 15552 cylinders assembled with a rear trunnion mounting
- Wide range of mounting options
- Equipped for magnetic position detectors

Typical industries

- Machine Automation
- Packaging



AVENTICS™ Series RCM – Rotary Module



AVENTICS™ Series RCM – Rotary Module

High torque with a compact design

- Pneumatic double piston drive (rack/pinion) and a precise rotary flange guided without play
- High power density with optimum ratio of torque and space
- Compact design – High torque and functionality in the minimum amount of space

Typical industries

- Industrial Automation



AVENTICS™ Series GPC – Guided Precision Cylinders



AVENTICS™ Series GPC – Guided Precision Cylinders

The cylinder with built-in features

- Pneumatic actuator
- Linear guide with high side load capacity and high precision
- Anti-rotation
- Stroke adjustment (GPC-E and GPC-ST)
- Cost efficient solution
- Direct combinations with Easy-2-Combine

Typical industries

- Industrial Automation



AVENTICS™ Series PRA, TRB ISO Profile, tie rod cylinders



AVENTICS™ Series PRA, TRB ISO Profile, tie rod cylinders

The workhorse solution of norm cylinders

- According to ISO 15552
- Temperature range from -40°C – +150°C
- Available with ISO and INCH ports
- Lightweight, due to advanced profile, material optimised covers wide range of portfolio

Typical industries

- General industry
- Industrial automation



AVENTICS™ Series CCL-IS, CCL-IC clean ISO cylinders



AVENTICS™ Series CCL-IS, CCL-IC clean ISO cylinders

Clean line as standard

- Compact, hygienic design
- Smooth surfaces, easy to clean
- Advantage: One side air supply
- Ideal for applications in the food industry

Typical industries

- Power
- Chemical
- Oil & Gas
- Other Industries



AVENTICS™ Series RTC rodless cylinders



AVENTICS™ Series RTC rodless cylinders

Compact versatile design and unique features

- The oval piston enables higher loads and torques, and highly compact designs
- Minimal leakage and a wide range of speeds thanks to a special internal sealing strip and grease
- One-piece slide and piston increase stability
- 3 Guide versions allow wide range of applications

Typical industries

- General industry
- Industrial automation



AVENTICS™ Series MSC guided cylinders



AVENTICS™ Series MSC guided cylinders

Highly modular design to suite your exact application

- Compact and strong
- Maximum useful load and maximum rigidity
- Functional design
- Low-maintenance

Typical industries

- Industrial automation



AVENTICS™ Series CAT Cushioning Adjustment Tool



AVENTICS™ Series CAT Cushioning Adjustment Tool

The easy way for the correct end cushioning adjustment

- Cost savings – possible to select smaller and more economical cylinders, valves and peripherals
- Fast, accurate and reproducible cushioning adjustment result
- Reduction of vibrations and oscillations in the system

Typical industries

- General industry
- Industrial automation



ASCO Numatics™ Series 307 push button microvalves



ASCO Numatics™ Series 307 push button microvalves

Easy to assemble, safe and robust push button valves

- Option of metal or plastic buttons
- Wide choice of pilot operators
- Microvalve button has a safe and robust fitting

Typical industries

- General industry



AVENTICS™ Series 740, 840 poppet valves



AVENTICS™ Series 740, 840 poppet valves

All-purpose diaphragm poppet valves with polyamide housing

- Cost-efficient and robust series
- Suitable for all air qualities
- For consistently high repeatability
- Base plate assembly and block assembly possible
- Versions also available with UL and ATEX coils
- Low operating pressure: min. 1.5 bar.

Typical industries

- General industry
- Industrial automation
- Food & Beverage



AVENTICS™ Series TC08, TC15 single valves



AVENTICS™ Series TC08, TC15 single valves

Robust and flexible

- Excellent ratio of installation space and flow rate
- Large selection of electrical connections
- Electrical or pneumatic operation
- Long service life
- Coil adjustable in 4 positions by 90° each

Typical industries

- General industry
- Industrial automation



ASCO Numatics™ Series 286 poppet valves

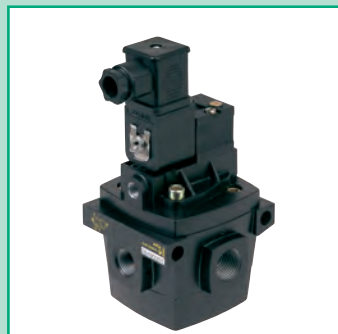

ASCO Numatics™ Series 286 poppet valves

Large flow poppet valve suitable for individual or joined use

- 1 1/2" port size, flow up to 35000 l/min, operating pressure 2-16 bar, 3/2, NC, NO and 4/2 air and solenoid air operated
- Short response times for high cycle applications
- Optional flow regulator to optimise pneumatic cabling

Typical industries

- General industry
- Packaging



ASCO Numatics™ Series G34 poppet valves



ASCO Numatics™ Series G34 poppet valves

ISO size 3 poppet valves

- ISO 5599/1 subbase-mounting body
- Modular assembly with joinable subbases. Subbase with side or bottom ports
- Valves have a reliable sturdy construction, and a fast response time

Typical industries

- Machine Automation
- Packaging



AVENTICS™ Series CD04, CD07, CD12 single valves



AVENTICS™ Series CD04, CD07, CD12 single valves

Particularly resistant for demanding environments

- Durable die-cast zinc housing
- Mechanically operated versions
- Assembly on base plate
- Suitable for extreme ambient temperatures
- Resistant to voltage fluctuations
- ATEX versions

Typical industries

- General industry
- Industrial automation
- Truck/Automotive Upfitter



AVENTICS™ Series 490, 579, 589 poppet valves



AVENTICS™ Series 490, 579, 589 poppet valves

Robust, lightweight and quick to assemble

- Cost-efficient series
- Integrated connections
- Individual or block assembly
- Extensive voltage range
- Series suitable for dusty environments

Typical industries

- General industry
- Industrial automation



AVENTICS™ Series CD01, CD02 valves according to ISO 15407-1



AVENTICS™ Series CD01, CD02 valves according to ISO 15407-1

Comprehensive series of ISO 15407-1 valves

- Large portfolio of electrical connections

Typical industries

- General industry
- Industrial automation
- Automotive



AVENTICS™ Series LS04 single valves



AVENTICS™ Series LS04 single valves

Best-in-class compactness for embedded solutions

- Compact and light
- Quick switching
- Easy to integrate
- Very reliable
- Suitable for mobile applications

Typical industries

- Industrial automation



AVENTICS™ Series AP mechanically operated poppet valves



AVENTICS™ Series AP mechanically operated poppet valves

Lightweight, versatile and robust

- Light and resilient valves
- Various mechanical actuating controls
- Panel installation

Typical industries

- General industry
- Industrial automation



AVENTICS™ Series ST spool valves

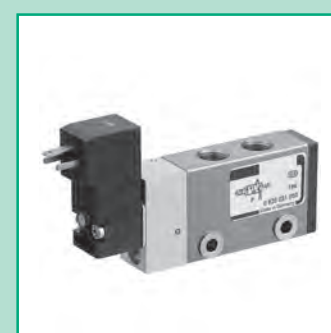

AVENTICS™ Series ST spool valves

Metal sealing system for demanding industrial applications

- Very robust valves for demanding environments
- Various mechanical actuating controls
- Panel installation

Typical industries

- General industry
- Industrial automation
- Food & Beverage



AVENTICS™ Series 563, 565, 567 poppet valves



AVENTICS™ Series 563, 565, 567 poppet valves

- Great capacity and endurance**
- Very robust
 - Block assembly
 - Suitable for high flow rate / high working pressure
 - Reliable even in harsh environments
 - Application temperature up to +120°C for versions with pneumatic operation

- Typical industries**
- General industry
 - Industrial automation



ASCO Numatics™ Series 608, 609 Sentronic D



ASCO Numatics™ Series 608, 609 Sentronic D

- From static to high dynamic and high accuracy**
- Quick response times
 - High sensitivity
 - Dual loop control option

- Typical industries**
- Food & Beverage
 - Medical & Life Science
 - Power
 - Analytical and Medical Industry
 - Automotive & Tyre



AVENTICS™ Series ED05 proportional valves



AVENTICS™ Series ED05 proportional valves

- Robust cost-effective plug & play proportional regulator**

- Robust poppet Valve
- 3/3 way valve directly controlled by proportional solenoid
- Universally applicable

- Typical industries**
- General industry
 - Industrial automation
 - Rail Industries
 - Truck Industries



AVENTICS™ Series ED07, ED12 proportional valves

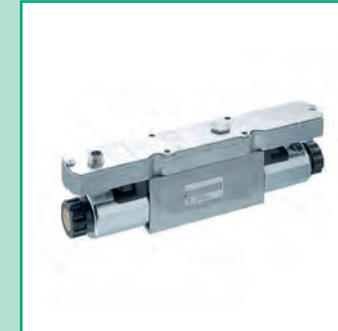

AVENTICS™ Series ED07, ED12 proportional valves

- Best performer in dynamics and accuracy**

- Very high accuracy and dynamic by 2x 2/2 way valves
- Various Pressure Ranges (-1 to 30 bar)
- External sensor connection available

- Typical industries**
- General industry
 - Industrial automation
 - Glass Industries
 - Laser Cutting Industries



ASCO Numatics™ Series 614 Sentronic Plus



ASCO Numatics™ Series 614 Sentronic Plus

- Industry 4.0 and IIoT capable proportional valve**
- Available with integrated IO-Link® communication technology
 - High pressure (725 psi) version
 - Dual loop control option

- Typical industries**
- Food & Beverage
 - Medical & Life Science
 - Analytical and Medical Industry
 - Automotive & Tyre
 - Life Science



ASCO Numatics™ Series 617 Sentronic LP



ASCO Numatics™ Series 617 Sentronic LP

- Industry 4.0 and IIoT capable proportional valve**
- Available with integrated IO-Link® communication technology
 - Low power consumption (3.8 W)
 - Digital communication and control

- Typical industries**
- Food & Beverage
 - Other Industries
 - Analytical and Medical Industry
 - Automotive & Tyre



AVENTICS™ Series EV03, EV05 AV-EP proportional valves



AVENTICS™ Series EV03, EV05 AV-EP proportional valves

- The valve system regulator**
- Low power consumption
 - Switch output possible
 - Two sizes available
 - Integrateable into AS valve systems

- Typical industries**
- General industry
 - Industrial automation



AVENTICS™ Series EV12 proportional valves



AVENTICS™ Series EV12 proportional valves

- The high flow regulator not only for air preparation units**
- High Flow Valve
 - Stackable
 - Pressure stays constant under usage
 - Integrateable into AS FRL series

- Typical industries**
- General industry
 - Industrial automation

ASCO Numatics™ Series 616 Sentronic HD



ASCO Numatics™ Series 616 Sentronic HD

- From static to high dynamic and high accuracy**
- High precision & accuracy
 - Air piloted with proportional valves
 - Select between 3 sets of saved control parameters

- Typical industries**
- Food & Beverage
 - Medical & Life Science
 - Other Industries
 - Analytical and Medical



AVENTICS™ Series ED02 proportional valves



AVENTICS™ Series ED02 proportional valves

- Smallest package for high dynamic plug & play applications**

- Highly accurate and dynamic by 2x 2/2 way proportional valves
- Stackable without baseplate
- Small space requirements

- Typical industries**
- General industry
 - Industrial automation
 - Food & Beverage



ASCO™ Series 263 solenoid valves



ASCO™ Series 263 solenoid valves

- A 2/2 valve for various media, such as steam and cryogenic fluids**

- Wide range of orifice sizes, pressure ratings, and resilient materials provide long service life and low internal leakage
- High flow valves for liquid, corrosive, and air/inert gas service
- Industrial applications include: car wash, air compressors, pumps, laundry equipment, industrial water control

- Typical industries**
- Special service industries



AVENTICS™ Series AV03, AV05 electro-pneumatic valve systems



AVENTICS™ Series AV03, AV05 electro-pneumatic valve systems

- The advanced valve system – perfect for complex automation solutions**

- The flexible, modular concept offer optimised solutions
- Future orientated, ready for IoT solutions
- Easy to use: online configurator and service friendly

- Typical industries**
- Industrial automation
 - Food and beverage
 - Other industries



AVENTICS™ Series AES fieldbus electronics and I/O



AVENTICS™ Series AES fieldbus electronics and I/O

The advanced electronic system – your interface to the superior controller

- Interface to valve series AV, HF and CD-PI via CANopen, DeviceNet, EtherNet IP, Profinet, Profibus - DP, EtherCat, and Powerlink
- Small size and weight
- Future oriented, ready for IIoT solutions

Typical industries

- Industrial automation
- Food and beverage
- Other industries



AVENTICS™ Series ES05 electro-pneumatic valve system



AVENTICS™ Series ES05 electro-pneumatic valve system

The essential valve system – simple, flexible, efficient

- Easy assembly
- High flexibility
- Cost focussed

Typical industries

- General industry
- Industrial automation



ASCO Numatics™ Series 580 fieldbus electronics and I/O



ASCO Numatics™ Series 580 fieldbus electronics and I/O

Compact, cost-efficient valve island for pneumatic control

- Compact Communication Node with configuration and System Status Diagnostics via LED Display
- Interfaces to many valve Series, including 501, 502 and 503, with flow ranges from 400 to 3820 l/min
- Comes with a large range of communications options, including IO-Link, CHARMs, DeviceNet, Profinet and Profibus – DP.

Typical industries

- Food & Beverage
- Medical & Life Science
- Automotive & Tyre
- Other Industries



AVENTICS™ SPM – Smart Pneumatics Monitor IIoT gateway



AVENTICS™ SPM – Smart Pneumatics Monitor IIoT gateway

IIoT Gateway

- Edge computing capabilities to create useful information and analysis out of sensor data
- Local data collection and analysis independent of the control or any cloud
- Support of OPC-UA, MQTT and different clouds

Typical industries

- General Industry
- Industrial Automation



AVENTICS™ Series CL03 electro-pneumatic valve systems with hygienic design



AVENTICS™ Series CL03 electro-pneumatic valve systems with hygienic design

CL03 - the clean line valve system

- Hygienic Design
- Modular and flexible
- High flow up to 1.100 l/min

Typical industries

- Food and beverage



AVENTICS™ Series 581 valves according to ISO 5599-1



AVENTICS™ Series 581 valves according to ISO 5599-1

Comprehensive Series of SO 5599-1 valves

- Size ISO 1 to 4
- Large portfolio of electrical connections
- High flow

Typical industries

- General industry
- Industrial automation
- Automotive



AVENTICS™ SPA – Smart Pneumatics Analyser



AVENTICS™ SPA – Smart Pneumatics Analyser

The IIoT solution in a box

- Portable to analyse different machines
- Everything inside to start with IIoT
- Direct access to visualisation and statistical information of the machine

Typical industries

- General Industry
- Industrial Automation



AVENTICS™ Series ECD – Ejector Compact



AVENTICS™ Series ECD – Ejector Compact

Intelligent

- Condition monitoring
- With display and IO-Link
- Air safe function for pick and place applications

Typical industries

- Industrial Automation



ASCO Numatics™ Series 501, 502, 503 zoned safety valve islands



ASCO Numatics™ Series 501, 502, 503 zoned safety valve islands

Improve productivity and reduce cost and complexity

- Simplifies the design of a Cat 3 pneumatic safety circuit (compatible up to PLd) by integrating the safety function into a pneumatic valve island
- Allows multiple independent safety circuits (up to 3) to be cost effectively designed into a single pneumatic valve island
- Evaluated by TÜV Rheinland (Report No. 968/FSP 1228.00/16) in accordance with ISO 13849-1

Typical industries

- Automotive & Tyre
- Packaging



ASCO Numatics™ Series G3 fieldbus electronics and I/O

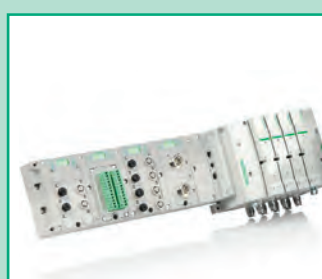

ASCO Numatics™ Series G3 fieldbus electronics and I/O

Electronics made easy!

- Innovative Graphic Display is used for easy commissioning, visual status & diagnostics
- Interfaces to many valve Series, including 501, 502 and 503, with flow ranges from 400 to 3820 l/min. Up to 128 coils per valve island
- Available with a large range of communications options, including DeviceNet, EtherNet, Profinet, Profibus - DP, EtherCat, Modbus TCP and Powerlink

Typical industries

- Other Industries
- Automotive & Tyre
- Food & Beverage
- Medical & Life Science



AVENTICS™ Series EMS – Ejector Multistage



AVENTICS™ Series EMS – Ejector Multistage

Powerful

- Efficient eco nozzle technology
- High suction capacity
- Simple and fast maintenance

Typical industries

- Industrial Automation



AVENTICS™ Series NCT – Non-Contact Transport Systems



AVENTICS™ Series NCT – Non-Contact Transport Systems

Bernoulli principle

- Sensitively handling
- For delicate surfaces and difficult to grasp materials
- Direct contact with food product

Typical industries

- Industrial Automation



AVENTIS™ Series BSA, BSG, FSG, FSO, FSR, SGN vacuum suction grippers



AVENTIS™ Series BSA, BSG, FSG, FSO, FSR, SGN vacuum suction grippers

- Wide range**
- For gentle lifting and movement
 - Up to diameters of 300 mm
 - For workpieces with curved or inclined surfaces
- Typical industries**
- Industrial Automation



AVENTICS™ Series PE5 electrical pressure sensors



AVENTICS™ Series PE5 electrical pressure sensors

- High flexible and versatile pressure sensor**
- Easy to understand, reducing operating errors and saving time and money
 - Zero-point offset function, flexible use, more exact display and switching than ever
 - PNP, NPN and push-pull freely selectable
- Typical industries**
- General industry
 - Industrial automation



AVENTICS™ Series CCO2-AL check-choke valves



AVENTICS™ Series CCO2-AL check-choke valves

- Modular**
- High quality manufacturing
 - Modern and compact design
 - Simply tube mounting by improved push-in
- Typical industries**
- General industry
 - Industrial automation



AVENTICS™ Series QR1 quick release fittings



AVENTICS™ Series QR1 quick release fittings

- Numerous variants**
- Compact design and low weight
 - Optimum sealing through captive O-Ring
 - Easy release through oval release ring
- Typical industries**
- General industry
 - Industrial automation



AVENTICS™ Series SM6-AL distance measuring sensors



AVENTICS™ Series SM6-AL distance measuring sensors

- High flexible and versatile pressure sensor**
- Easy, secure and intuitive programming
 - Analog measurement for long distance
 - Wide range of possible applications
- Typical industries**
- General industry
 - Industrial automation



AVENTICS™ Series SC4 4 mm C-slot sensors



AVENTICS™ Series SC4 4 mm C-slot sensors

- Very short sensor housing enables use in short-stroke cylinders and grippers**
- Precise adjustment of switching width, five times more accurate than conventional cylinder sensors
 - Easy, fast installation with drop-in mounting
 - Excellent durability of the magnetic cylinder sensor
- Typical industries**
- General industry
 - Industrial automation



AVENTICS™ Series TU1, TU2 compressed air tubing



AVENTICS™ Series TU1, TU2 compressed air tubing

- High-quality**
- Different materials, colours and dimensions
 - Antistatic, Halogen-free
 - Resistance to high pressure, UV, microbes and hydrolysis
- Typical industries**
- Industrial automation
 - Food



AVENTICS™ Series ST6 position sensors



AVENTICS™ Series ST6 position sensors

- Universal magnetic proximity sensor**
- 6mm T-Slot groove
 - Drop-in mounting and fixing via captive screw
 - Cold- and heat resistant version available
 - Reed and electronic PNP or NPN
- Typical industries**
- General industry
 - Industrial automation



AVENTICS™ Series CP2 TWO-stage safety couplings



AVENTICS™ Series CP2 TWO-stage safety couplings

- Safety**
- Preventing the dangerous "bullwhip effect"
 - Very robust and durable
 - Ergonomically shaped
- Typical industries**
- General industry
 - Industrial automation



ASCO™ Series RB poppet valves



ASCO™ Series RB poppet valves

Light-weight, highly customisable and compact valve for gas applications such as within portable medical devices

- Cycle life in the hundreds of millions
- Low power consumption and light weight offers extended battery life for portable devices
- Multiple body configurations to suite the application needs

Typical industries

- Analytical and Medical Industry



ASCO™ Series-S poppet valves



ASCO™ Series-S poppet valves

Light-weight and compact design for gas applications in portable medical devices

- Highly customisable solution
- Compact light-weight architecture and low power consumption make them ideal for portable medical devices
- Larger orifice sizes and vacuum capability make these valves extremely versatile across multiple disciplines

Typical industries

- Analytical and Medical Industry



ASCO™ Series 202 Preciflow IPC proportional valves



ASCO™ Series 202 Preciflow IPC proportional valves

Compact proportional valve with low power consumption, ideal for gas applications

- Ideal to precisely control flow rates in medical equipment and analytical instrumentation
- Compact construction saves valuable space in equipment
- Low hysteresis, excellent repeatability, and high sensitivity for precise flow control

Typical industries

- Analytical and Medical Industry



ASCO™ Series 630 Piezo valves



ASCO™ Series 630 Piezo valves

Miniature, ultra-low power consumption (0.004 W) proportional mini piezo-valves, with almost no heat dissipation

- Pad mounting proportional mini piezo-valves available with single subbase M5
- No wearing parts: practically unlimited service life
- No inductive peaks when switching: no circuit protection necessary

Typical industries

- Analytical and Medical Industry



ASCO™ Series 065 flat spring valves



ASCO™ Series 065 flat spring valves

High gas flow capacities and short response time with precise adjustment

- Medical analysers, gas analysers and leak detectors
- New flat-spring technology ensures no contamination of fluids
- Service life of more than 1 billion cycles

Typical industries

- Analytical and Medical Industry



AVENTICS™ Series MSV8 high flow cartridge valves



AVENTICS™ Series MSV8 high flow cartridge valves

Poppet valve for the analytical and medical industry

- High density, small size, light weight micro-solenoid valve
- 8 mm diameter, cartridge style
- 2/2 and 3/2 configurations available
- Best-in-class in flow/size ratio!

Typical industries

- Analytical and Medical Industry
- General industry



ASCO™ Series 624 pressure regulators



ASCO™ Series 624 pressure regulators

Non-relieving pressure regulator with manifold or pad mount interface for oxygen therapy or ventilation applications

- Designed to control the air pressure to match the requirements of the system by varying the flow through the regulator to maintain the set pressure
- Applicable for use with 99% concentrated oxygen (manifold)
- Lightweight, compact design

Typical industries

- Analytical and Medical Industry



AVENTICS™ Series CR1 pressure regulators



AVENTICS™ Series CR1 pressure regulators

Pressure regulator cartridge

- Aluminium body or cartridge style
- Cleaned for oxygen service
- Nominal flow Qn 250 l/min

Typical industries

- Analytical and Medical Industry



AVENTICS™ Series MSV12 high flow cartridge valves



AVENTICS™ Series MSV12 high flow cartridge valves

High flow miniature solenoid valve

- Cartridge style, very high flow, compact design
- Energy saving design for portable (battery operated) devices
- High cycle life

Typical industries

- Analytical and Medical Industry
- General industry



ASCO™ Series 202 Preciflow proportional valves



ASCO™ Series 202 Preciflow proportional valves

Precisely controls the flow rates on medical equipment and analytical instrumentation

- Compact design saving valuable space in equipment
- Low hysteresis, excellent repeatability, and high sensitivity for precise flow control

Typical industries

- Analytical and Medical Industry



ASCO™ Series 067 rocker isolation valves



ASCO™ Series 067 rocker isolation valves

No sticking effect of the valve seat and reduced power consumption through integrated power save function

- Fluid Isolation
- Low Internal Volume
- Reduced Heat Exchange Between Coil and Fluid

Typical industries

- Analytical and Medical Industry



ASCO™ Series 068 flapper isolation valves



ASCO™ Series 068 flapper isolation valves

Used for heat sensitive reagents and biological samples in liquid applications

- Reduced heat transfer
- No pumping or sticking effect
- Prevention of contamination

Typical industries

- Analytical and Medical Industry



ASCO™ Series 110 rocker isolation valves



Miniature solenoid valves for medical analysers, biotechnology and gas analysers

- Can be used to control acids and bases, as well as analytical reagents
- Any application where the fluid may not come into contact with metal parts and with the electromagnetic control section of the solenoid valves

Typical industries

- Analytical and Medical Industry



ASCO™ Series 383 lever isolation valves



Solenoid valves for medical analysers, biotechnology and chemical industry

- Ideal solenoid valves to control corrosive fluids
- The solenoid valves satisfy all relevant EC directives

Typical industries

- Analytical and Medical Industry



ASCO™ Series 290 pressure operated valves



Angle seated valve for the control of multiple fluids, used for proportional and on/off applications

- Long service life, maintenance free actuators
- Many options and variations available, including proportional and motorised versions
- Available for food contact applications

Typical industries

- Food & beverage
- General industry



ASCO™ Series 298 pressure operated valves



Robust globe valves for tyre and process industry applications

- Robust design, built to withstand steam, superheated water and corrosive fluids
- Resistant to thermal shocks
- Large range of options and versions, including proportional

Typical industries

- Water and Wastewater
- Automotive & Tyre
- Chemical



ASCO™ Series 284 pinch valves



Media separated valve for maximum purity through hermetic separation of fluid and valve body

- Solenoid valve suitable for cutting off the flow of a fluid by pinch
- For sterile, aseptic, physiological and food applications
- No turbulence, silent operation

Typical industries

- Analytical and Medical Industry



ASCO™ Series 055 diaphragm isolation valves



Ideal for highly aggressive liquids due to a virtually impervious diaphragm

- The PTFE body and diaphragm isolates the internal solenoid components from the media resulting in a virtually impervious valve
- Excellent self-draining capability and easy-to-flush low-volume internal cavity
- Compact architecture make them ideal for analytical bench-top instrumentation

Typical industries

- Analytical and Medical Industry



ASCO™ Pure-Flo aseptic diaphragm valves



Pure-Flo aseptic valves, high purity diaphragm valves

- From standard forged to the most innovative block technology
- Stainless steel body with PAS, PBT or stainless steel actuator
- Manually or air operated

Typical industries

- Life science
- Food & Beverage



ASCO™ Series 342 stainless steel air preparation products



Filter Regulators suitable for the aggressive environments of many process industries.

- 316L stainless steel, corrosion resistant and robust
- Wide temperature range: -60°C to +90°C
- ATEX, CUTR, SIL (up to 2) certified and NACE compliant

Typical industries

- Chemical
- Oil & Gas
- Food & beverage
- Life science



ASCO™ Series 252 modular dental manifold



Complete solution for fluid handling in dental chairs

- Designed for use with air and mild liquids
- Plug & Play construction is easily integrated into existing chair configurations due to its compact design
- Each of the three channels on the manifold is equipped with a flow regulator to adjust the water and air flow according to the specific customer requirements

Typical industries

- Analytical and Medical Industry



ASCO™ Series 327 solenoid valves



'Industry standard' direct acting, universal solenoid valve for piloting process actuators.

- Balanced poppet design for high flow at minimum power levels
- Wide temperature range: -60°C to +90°C
- ATEX, CUTR, SIL certified and NACE compliant

Typical industries

- Power
- Chemical
- Oil & Gas
- Other Industries



ASCO™ Series 551 solenoid valves



Pilot operated solenoid valve for controlling process valve actuators

- Resistant to harsh environments enabled by "non-breathing" design
- Many different material and construction variations, suitable for many applications
- Global certification, including ATEX, CUTR, UL, SIL, and more

Typical industries

- Power
- Chemical
- Oil & Gas
- Life Science



ASCO™ Series 320 solenoid valves



ASCO™ Series 320 solenoid valves

Wide range of 3/2 direct acting valves, with many options

- Large choice of poppet valves with tight shutoff
- Wide range of elastomers for specialty service, and enclosures to suit all environments
- Mountable in any position

Typical industries

- General industry



ASCO™ Series 238 solenoid valves



ASCO™ Series 238 solenoid valves

Compact range of cost efficient pilot operated valves

- Compact design saves space, reduces installation time, and simplifies service
- Short stroke design increases life

Typical industries

- General industry



ASCO™ Series 330 volume boosters



ASCO™ Series 330 volume boosters

Process valve volume booster for on/off and control applications

- Available in both 316L stainless steel and hard anodised aluminium
- Wide temperature range: -60°C to +90°C
- ATEX, CUTR, SIL certified and NACE compliant

Typical industries

- Chemical
- Oil & Gas



ASCO Numatics™ Series 580 CHARMS valve islands



ASCO Numatics™ Series 580 CHARMS valve islands

Save time and cost with a revolutionary approach to distributed valve island control

- Provides single connection from the field to DeltaV™ with Electronic Marshalling
- Uses native capabilities of DeltaV for diagnostics of pneumatic valves
- Brings redundant communication and power connections to pneumatic valve islands

Typical industries

- Medical & Life Science
- Chemical



ASCO™ Series 210 solenoid valves



ASCO™ Series 210 solenoid valves

General purpose pilot operated 2/2 solenoid valve with many options

- Wide range of pipe sizes, pressure ratings, and resilient materials provide long service life and low internal leakage
- High flow valves for liquid, corrosive, and air/inert gas service
- Industrial applications include: car wash, air compressors, pumps, laundry equipment, industrial water control

Typical industries

- General industry



ASCO™ Series 262 solenoid valves



ASCO™ Series 262 solenoid valves

General purpose direct acting 2/2 solenoid valve with many options

- Wide range of pipe sizes, pressure ratings, and resilient materials provide long service life and low internal leakage
- High flow valves for liquid, corrosive, and air/inert gas service
- Industrial applications include: car wash, air compressors, pumps, laundry equipment, industrial water control

Typical industries

- General industry



ASCO™ Series 800 accessory valves for actuator control



ASCO™ Series 800 accessory valves for actuator control

Accessory valves complete the valve actuator control portfolio

- 316L stainless steel accessory valves
- 1/4 and 1/2" port sizes
- All accessory valves are compatible with our other products and solutions

Typical industries

- Chemical
- Life Science
- Oil & Gas
- Food & beverage



Anderson Greenwood™ Series 5L GRP enclosure



Anderson Greenwood™ Series 5L GRP enclosure

Cost effective GRP enclosure to protect site equipment from detrimental external weather or climate conditions

- Durable & IP66 compliant
- 3 sizes with base or wall mounted options
- Sunshade versions available

Typical industries

- Industrial
- Oil & Gas



ASCO™ Series 292, 293 solenoid valves



ASCO™ Series 292, 293 solenoid valves

Designed for use in petrol vending applications

- Compact aluminium threaded and flanged bodied valves, offering single and dual flow constructions for petrol vending applications
- Explosion proof operators, for use within potentially explosive areas
- Easy electrical installation supplied with a pre-moulded 2m electrical cable

Typical industries

- Fuel dispensing



ASCO™ Series 353 dust collector solenoid valves



ASCO™ Series 353 dust collector solenoid valves

Pulse valves for dust collector applications

- Combines high flow, long life and extremely fast opening and closing
- Integral compression fittings for fast, easy, secure installation
- The high quality diaphragms are reinforced and wear resistant to guarantee a long operating life

Typical industries

- Other Industries
- Power
- Automotive & Tyre
- Chemical
- Air filtration



AVENTICS™ PN cylinders with sensor



AVENTICS™ PN cylinders with sensor

- Single-acting working unit with spring return
- With or without position sensor
 - DIN type electrical connector or pigtail cable
 - 0 – 10 bar / - 40 up to +120°C
 - Cylinder diameters 25, 32 and 40 mm
- Typical industries
- Engine
 - Transmission



AVENTICS™ universal actuators



AVENTICS™ universal actuators

- Universal actuator to drive and control applications for air management on engine or actuation for chassis, cab and transmission
- Operating Temperature: - 40°C to 150°C
 - Accuracy: <0.5°
 - Torque: 20.0N-m @ Peak Torque
 - Motor: BL/PM-DC, 12V/24V
- Typical industries
- Engine
 - Transmission
 - Chassis/Bus
 - Up-Fitter
 - Cabin
 - Aerodynamics



AVENTICS™ air valve unit



AVENTICS™ air valve unit

- Used for buffer air function control in diesel engine applications. A solenoid valve is used to close air feed when the engine is stopped or when the pressure from engine air inlet manifold is high enough to supply buffer air
- Shuttle/pressure reducing valves
 - Pressure range: 3.5 – 12 bar
 - -40 up to +120°C
 - Flow range 0 – 20 l/min
 - Controlled pressure 0.8 bar
 - 12 or 24 Volt DC
- Typical industries
- Engine
 - Transmission



AVENTICS™ throttle valve daimler (for axles)



AVENTICS™ throttle valve daimler (for axles)

- Oil level control in truck rear axle to reduce friction losses while driving
- Fuel efficiency improvement
 - Integrated cylinder driving a flap valve
 - Spring return
 - Defined flow in closed position
- Typical industries
- Axle



AVENTICS™ VGT turbo actuators



AVENTICS™ VGT turbo actuators

- Altering the geometry of the turbine housing as the engine accelerates, the turbo's aspect ratio can be maintained at its optimum
- Quick response time (T90 at 0.1s)
 - Operational -40°C to +130°C
 - CAN Bus controlled
 - Max. con. torque 4 Nm
 - Position accuracy [%] +/-1
- Typical industries
- Engine



AVENTICS™ pressure reducers



AVENTICS™ pressure reducers

- Mechanical pressure regulator with fixed set point. To increase the service life of pneumatic components and actuators
- Protection from pressure spikes
 - Pressure limitation for different applications
- Typical industries
- Engine
 - Transmission



AVENTICS™ steering wheel adjustment valves



AVENTICS™ steering wheel adjustment valves

- Manual valve for steering wheel adjustment
- Unique memory function
 - 3/3 and 4/4 way valve
 - High degree of function integration
 - Customer interface and design
- Typical industries
- Cabin
 - Seat



AVENTICS™ hot side dual flap EGR valves (Active)



AVENTICS™ hot side dual flap EGR valves (Active)

- The EGR valve feeds exhaust gas back into the combustion chamber. With the fuel/air mixture thus diluted, combustion temperatures are reduced
- Single or Dual Bore Configuration
 - Bore Sizes from 35mm to 140mm
 - Flange Mount or V-Band Mount
 - Liquid Cooled
 - Up to 50.0N-m torque Peak at output shaft
 - <0.5° Position Accuracy
- Typical industries
- Engine



AVENTICS™ Series ED03 pressure control valves (proportional)



AVENTICS™ Series ED03 pressure control valves (proportional)

- Electropneumatic pressure control valves
- Low hysteresis
 - High regulation precision
 - Exemplary dynamics
 - Adaptation to customer application
 - Through software
- Typical industries
- Engine
 - Transmission



AVENTICS™ clutch valve unit



AVENTICS™ clutch valve unit

- The clutch valve unit is attached to the clutch housing and used in a system with automated manual transmissions (AMT) in trucks
- Four direct operated 2/2 solenoid valves
 - Electrical connection to control system via pigtail cable
 - 0 to 12 bar, -40 to +110°C
 - Voltage: 12 or 24 DC
- Typical industries
- Transmission



AVENTICS™ passive intake throttle valves



AVENTICS™ passive intake throttle valves

- With stricter emissions standards Intake throttle valves are used to reduce the amount of fresh air in the piston at part load condition to control temperatures and thereby minimise NOx production
- Bore sizes from 40mm to 280mm
 - Various mounting configurations
 - Integrated actuator
 - T90 < 80ms
 - Ts < 100ms
 - -40°C to 150°C operational (option)
- Typical industries
- Engine
 - Transmission



AVENTICS™ check valves



AVENTICS™ check valves

- Mechanical check valve for protection of pneumatic valves against high back pressures. Developed for low opening pressures and includes a pressure sensor
- Pressure range: 0 – 4.5 bar (max 9 bar)
 - Temperature range: -40 up to +120°C
 - Protection class: IP69K
 - Pressure sensor
- Typical industries
- Engine
 - Transmission
 - Industry Application



AVENTICS™ 30 bar block valves



AVENTICS™
30 bar block valves

- Marine 30 bar 3/2 way block valve
- NO/NC/selector
 - NW7
 - Type approval DNV-GL

- Typical industries
- Marine
 - Engine Control



AVENTICS™ control head type 244



AVENTICS™
control head type 244

- Marine Marex OS III control head for ship propulsion control
- Reversion gear
 - Controllable pitch propeller
 - CAN bus interface
 - Type approval ABS, BV, CCS, DNV-GL, KRS, LR, RMRS
 - -25°C to 70°C
 - IP 66

- Typical industries
- Marine
 - Ship Controls



AVENTICS™ display type 230



AVENTICS™
display type 230

- Marine Marex OS graphical display
- Reversion gear
 - Controllable pitch propeller, hybrid
 - 2 CAN busses
 - Type approval ABS, BV, CCS, CRS, DNV-GL, KRS, LR, RMRS
 - -20°C to 70°C
 - IP 66

- Typical industries
- Marine
 - Ship Controls
 - Engine monitoring



AVENTICS™ E/P converter NW3



AVENTICS™
E/P converter NW3

- Marine E/P converter NW3 for engine RPM, CPP
- 0-6 bar
 - Hysteresis 0.02 bar
 - Filter 50 µm
 - Type approval DNV-GL

- Typical industries
- Marine
 - Oil & Gas



AVENTICS™ control head type 500



AVENTICS™
control head type 500

- Marine Marex ECS control head for ship propulsion control
- Reversing gear
 - CAN bus interface
 - WIFI interface
 - -25°C to 76 °C
 - IP 67

- Typical industries
- Marine
 - Ship Controls



AVENTICS™ control unit type MPC



AVENTICS™ control unit
type MPC

- Marine Marex OS propulsion controller
- Analogue and Digital In-/Outputs
 - 3 CAN busses
 - On board HMI
 - Reversing gear and controllable pitch propeller, hybrid
 - PLC included
 - More than 1000 parameter
 - -20°C to 70°C

- Typical industries
- Marine
 - Ship Controls



AVENTICS™ joystick type 531



AVENTICS™
joystick type 531

- Marine Marex 3D Joystick for ship propulsion control
- XYZ axis joystick
 - Centre return
 - CAN bus interface
 - Type approval DNV-GL, LR
 - -25°C to 70°C
 - IP 66

- Typical industries
- Marine
 - Ship Controls



AVENTICS™ redundant pressure reducing station



AVENTICS™
redundant pressure
reducing station

- Marine redundant pressure reducing station
- 40 bar in
 - 3 to 9.5 bar out
 - 1400 NI/min
 - Redundant
 - Type approval DNV-GL

- Typical industries
- Marine
 - Engine Control



AVENTICS™ control unit type ECS



AVENTICS™ control unit
type ECS

- Marine Marex ECS propulsion controller
- Analogue and Digital In-/Outputs
 - 2 CAN busses
 - Reversing gear
 - -20°C to 76°C
 - IP 67

- Typical industries
- Marine
 - Ship Controls



AVENTICS™ actuator type ECS



AVENTICS™
actuator type ECS

- Marine Marex ECS actuator
- Reversion gear
 - Throttle
 - 76/51 mm stroke
 - 150/225 N force
 - CAN bus interface
 - Type approval CCS
 - -15°C to 70°C
 - IP 66

- Typical industries
- Marine
 - Ship Controls



AVENTICS™ 3/2 way solenoid valves



AVENTICS™ 3/2 way
solenoid valves

- Marine 3/2 way valve for engine local control
- Start / Stop
 - NO/NC
 - 10 bar
 - 1200 NI/min
 - NW7
 - Type approval DNV-GL

- Typical industries
- Marine
 - Oil & Gas



AVENTICS™ Series NW25 30 bar solenoid valves



AVENTICS™ Series NW25
30 bar solenoid valves

- Marine 30 bar Start/Stop valve NW25 for engine start, stop, slow turning
- Engine start/stop
 - 6-30 bar
 - NW25
 - Type approval DNV-GL

- Typical industries
- Marine
 - Power Plants



Anderson Greenwood™ Series M25, M66A manifold



Anderson Greenwood™ Series M25, M66A manifold

Comprehensive range of hand gauge valves and manifolds for field instrument isolation

- Venting and calibration
- Remote and direct mount options
- Pressures up to 689 bar

Typical industries

- Industrial
- Oil & Gas



Anderson Greenwood™ Series HD33MK process valves



Anderson Greenwood™ Series HD33MK process valves

Process primary isolation valves for instrument tapping points

- Multiple configurations for isolation and vent functions
- Compact design, saving space and weight
- Compliant to piping class, fire safe, emissions standards

Typical industries

- Industrial
- Oil & Gas



Tescom™ Series Wega 200 pressure regulators



Tescom™ Series Wega 200 pressure regulators

Single stage pressure reduction regulator

- DIN compliant design
- Direct fixed assembly to medical devices
- Ability to fix present outlet pressure

Typical industries

- Medical



Tescom™ Series VA shut-off valves



Tescom™ Series VA shut-off valves

Air operated, high cycle life shut-off valve

- For pressures up to 1034 bar
- High flow capacity & option to integrate a solenoid valve (pneumatic assist)

Typical industries

- Industrial manufacturing & testing



Tescom™ Series ER5000 pressure regulators



Tescom™ Series ER5000 pressure regulators

Brings precise algorithmic pressure control to a wide range of applications

- Electro-pneumatic controller
- Precise algorithmic pressure control for mechanical regulators, gas & liquid applications from vacuum to 2068 bar

Typical industries

- Industrial manufacturing & testing



Tescom™ Series 26-2000 venting pressure regulators



Tescom™ Series 26-2000 venting pressure regulators

High pressure, low piston sensed regulator

- Versatile high-pressure range
- Low & medium flow piston sensed regulator, segregated captured venting
- Internal filter for increased serviced life, excellent choice for use with the ER5000

Typical industries

- Industrial manufacturing & testing



Tescom™ Series 20-1100 pressure regulators gas



Tescom™ Series 20-1100 pressure regulators gas

Compact lightweight aluminium high flow capacity regulator

- Provides stable outlet pressure & low droop over wide range of inlet pressures
- Integrated PRV & solenoid shut-off valves
- ECE-R 110 approved.

Typical industries

- Alternative Energy



Tescom™ Series PH3200 single stage regulators



Tescom™ Series PH3200 single stage regulators

High purity, medium flow single stage precision regulator

- Compact, USP, FDA and BPE compliant design, suitable for biotech and pharmaceutical applications
- Diffusion resistant metal-to-metal diaphragm seal to maintain gas purity and integrity

Typical industries

- Life Science



TopWorx™ Series K switch boxes



TopWorx™ Series K switch boxes

Versatile range of switch boxes for standard and special applications

- Available with linear option for Linear feedback
- Variations for ambient temperatures up to 400°C, highest in the market
- Field proven and tested successfully beyond 1 million operations

Typical industries

- General industries
- Industrial
- Medical & Life Science



TopWorx™ Series K switch boxes for subsea applications



TopWorx™ Series K switch boxes for subsea applications

Switch box for sub-sea applications

- Applications Sub-sea, Floating Production Storage and Offloading (FPSO), and oil rigs
- Ingress protection – down to 400 metres

Typical industries

- Oil & Gas



TopWorx™ Series D switch boxes



TopWorx™ Series D switch boxes

Switch box for advanced applications

- Variety of Bus Networks and Sensor Options including HART with advanced diagnostics
- Intrinsically Safe, up to SIL 3, and ATEX certified, included flameproof options
- Suitable for heavy duty applications, scotch yoke actuators

Typical industries

- Oil & Gas



TopWorx™ Series T switch boxes



TopWorx™ Series T switch boxes

Compact switch boxes, ideal for rack & pinion actuators

- Available in aluminium, stainless steel & engineered resin
- Intrinsically Safe and ATEX certified
- Suitable for all (extreme) environments, including heavy wash down and corrosive environments

Typical industries

- Oil & Gas
- General industries
- Industrial



GO Switch™ Extended Sensing Range



GO Switch™ Extended Sensing Range

Proximity switch for use in harsh environments

- High maximum operating temperature: 176°C
- Single Pole Double Throw (SPDT), true Double Pole Double Throw (DPDT) and latching variations
- Various connections options

Typical industries

- General industries
- Industrial
- Oil & Gas
- Water and Wastewater
- Food & Beverage



GO Switch™ Series 52M proximity sensors



GO Switch™ Series 52M proximity sensors

Proximity switches for industrial & machine automation applications

- M12 compact proximity sensor
- 316L stainless steel housing
- Wide operating temperature range: -40° to 100°C

Typical industries

- General industries
- Industrial



GO Switch™ Precision Sensing Range



GO Switch™ Precision Sensing Range

Precision proximity switch for extreme applications, "fit and forget"

- Precision sensing for harsh environments
- Suitable for use in sub-sea, nuclear and hazardous areas (zone 0 or 1 ATEX approvals)
- Wide operating temperature range: -50° to 105°C





Typical industries

- General industries
- Industrial
- Oil & Gas
- Water and Wastewater
- Food & Beverage



For a complete contact directory and further information about the integration of Aventics within the Fluid & Motion Control business of Emerson, go to my.asco.com/sites/Aventics/Pages/Home



-  Emerson.com
-  Facebook.com/EmersonAutomationSolutions
-  LinkedIn.com/company/Emerson-Automation-Solutions
-  Twitter.com/EMR_Automation



Broader. Better. Together.
ASCO. AVENTICS. TESCO. TopWorx.

The Emerson logo is a trademark and service mark of Emerson Electric Co. Brand logotype are registered trademarks of one of the Emerson family of companies. All other marks are the property of their respective owners. © 2018 Emerson Electric Co. All rights reserved.

